



WITH HOT WATER

Extra C-Tap 2H

Specification Sheet

VIVREAU®



Extra C-Tap

- Five water types: unchilled and chilled still, chilled semi-sparkling, sparkling, and hot water
- Tap height: 16 1/4 inch
- Vivreau's ThermalGate™ feature protects against retrograde contamination from external sources
- Sustainable: high energy efficiency and natural refrigerant R290, harmless to the climate
- Premium design solution with a modern control panel and high-quality materials such as stainless steel
- Easy Access Panel, available as an additional control unit that can be positioned at different heights, e.g. B. for wheelchair users



Installation Requirements:

Millwork

- Worktop cutout on page 5
- Fits into base cabinet with the following dimensions (W X H X D): 30 X 29 1/2 X 24 inch
- Tap height plus additional 4" clearance for operation
- Cabinet ventilation: cabinet requires two vents, one for exhaust and one for air intake. (page 8)

Plumbing

Water Connection



1 potable 1/2" cold water supply terminating in a 1/2" ball valve with a 1/2" female pipe thread.

NOTE: Please ensure that there is sufficient room for a 12" long fitting to be connected to the shut-off valve

Waste Water Connection: (Choose one of the below options)

Option 1. Waste water pipe:

trapped up stand to facilitate a 1/2" flexible pipe (customer supplied). Max. 6 1/2" left or right of the system

Option 2. Waste water container: available for purchase

Water Supply

- Minimum water pressure 50 PSI
- Minimum water flow 80 Gallons per hour

Drip tray: Drain to connect 1/2" ID - 3/4" OD drip tray tube

Electrical

(2) 20amp electrical circuit GFCI recommended (NEMA 5-20R) 120V, 60Hz (11 amps)

CO2 (Customer supplied)

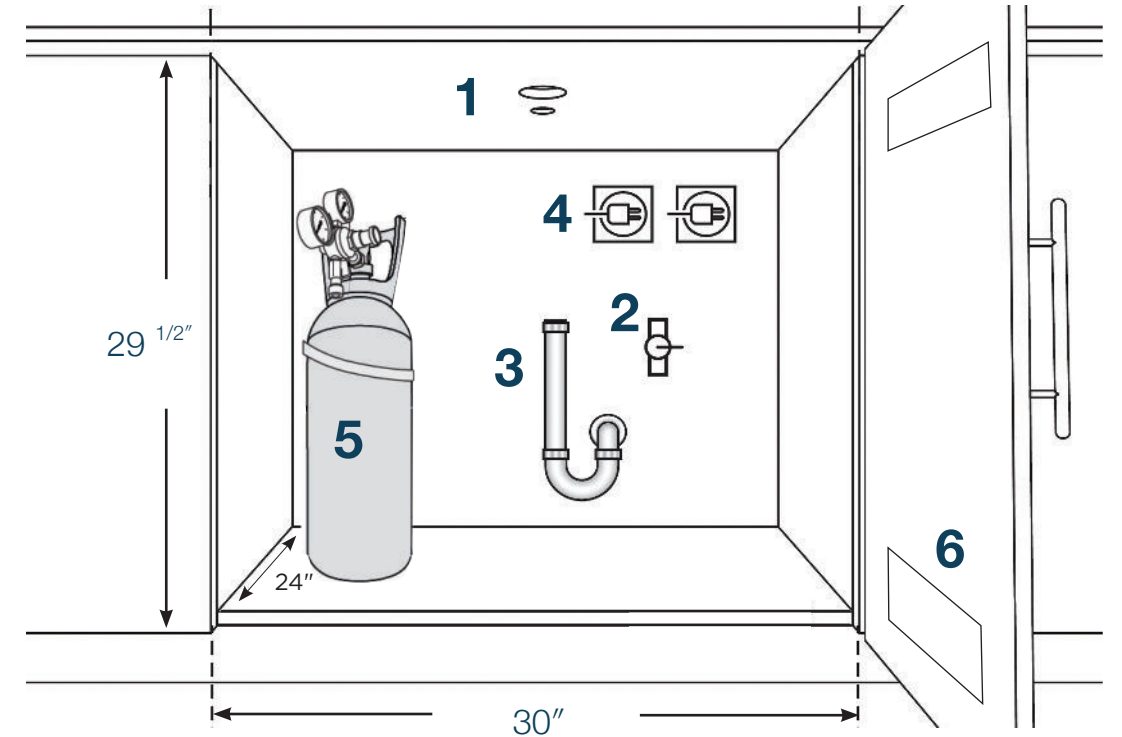

1. Millwork
2. Water Connection
3. Waste Water Connection
4. Electrical Connection
5. CO2 (customer supplied)
6. Ventilation (review page 8 for all approved methods of ventilation)

Equipment Dimensions



Dispensing tap

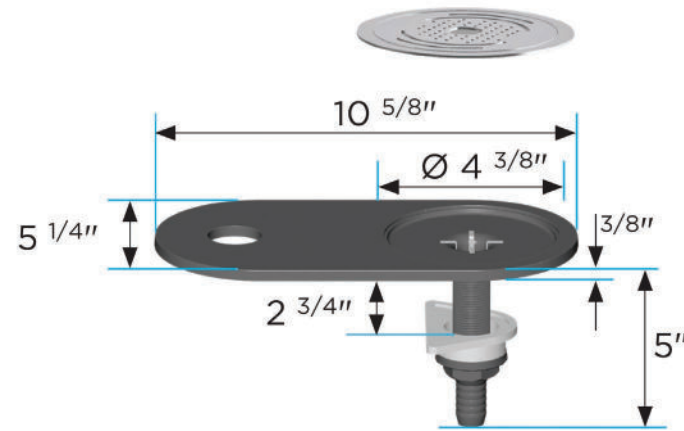

Drip Tray (integrated)

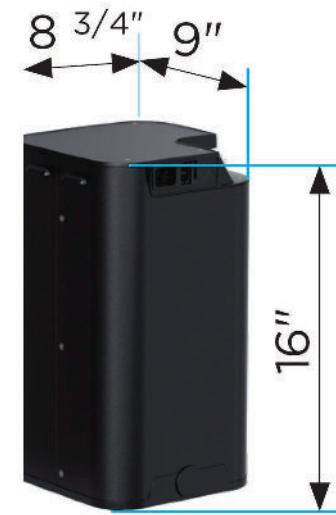

Boiler

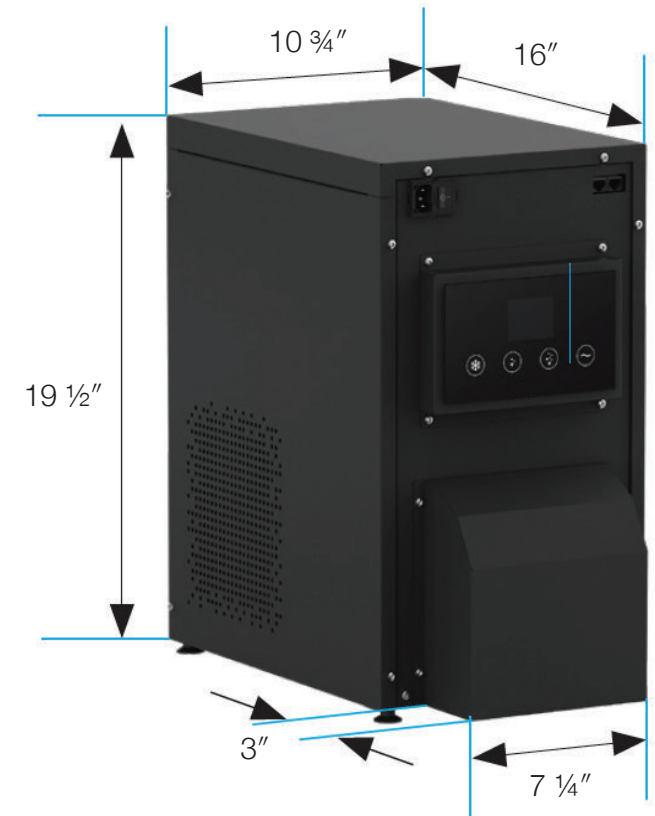

Cooler-carbonator

Extra C-Tap
Worktop Cutout

THIS DRAWING IS NOT TO SCALE

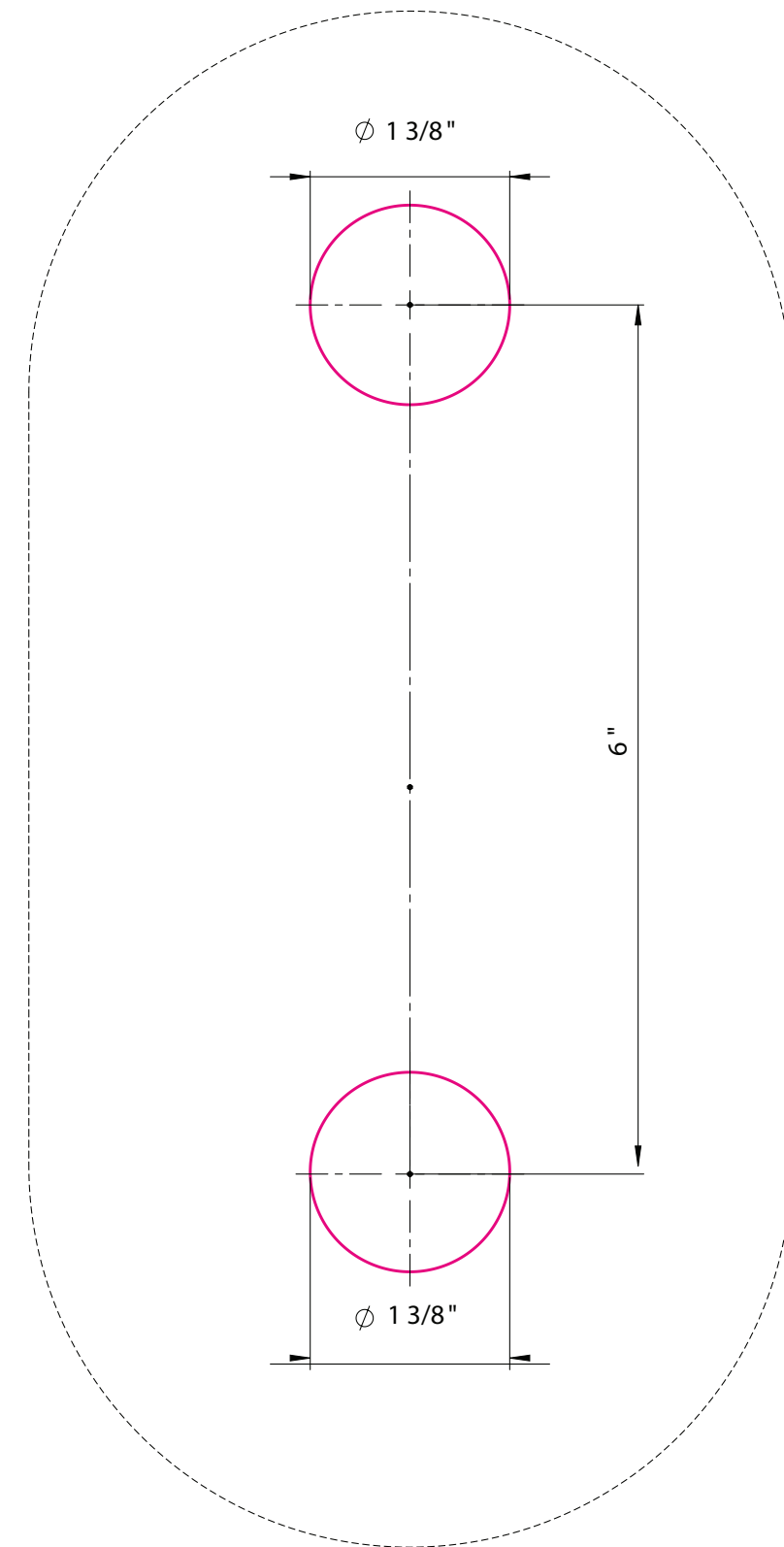

Drilling ———

Figure 1: Installation Requirements

- 1 Water Connection
- 2 Electrical Connection
- 3 Waste Water Connection
- 4 CO2 (customer supplied)
- 5 Ventilation
- 6 Countertop cutouts for tap

Figure 2: Arrangement and Dimensions

- a. Dispensing Tap
- b. Integrated Drip Tray
- c. Cooler Carbonator
- d. CO2 Tank
- e. CO2 Pressure Regulator
- f. Filter
- g. Optional Waste Water Container
- h. Boiler
- i. PURITY C Filter

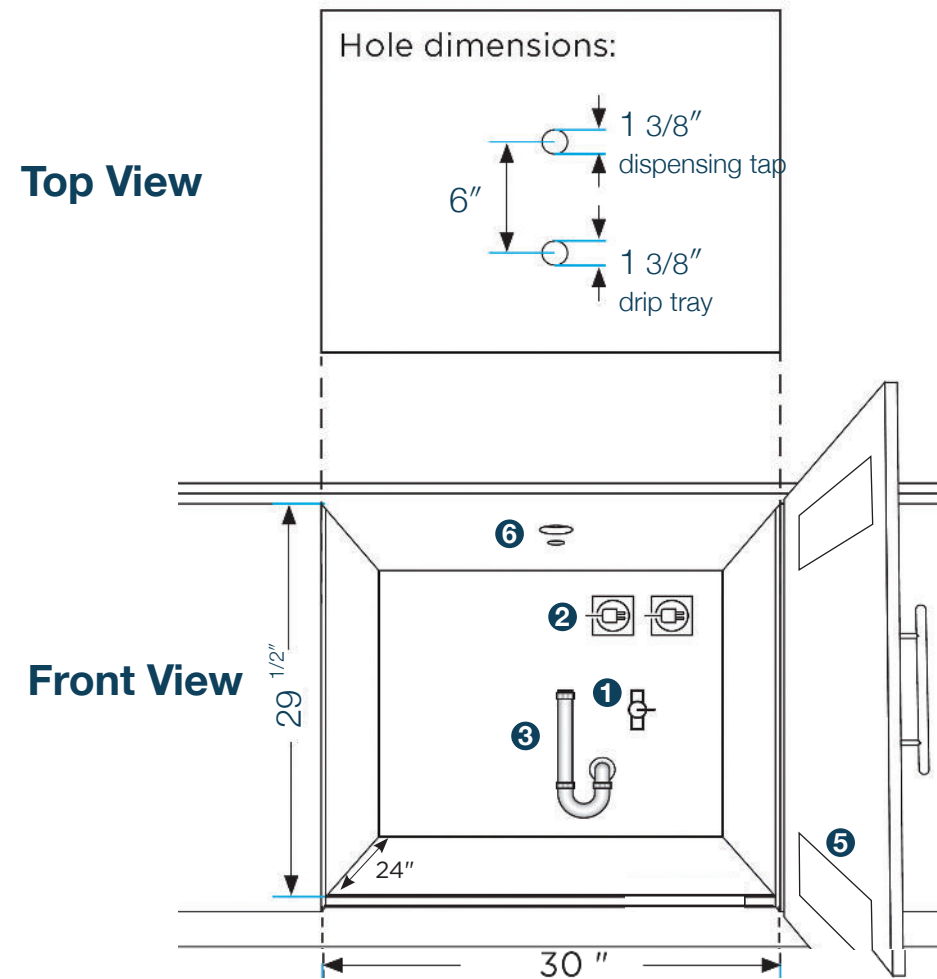

Figure 1

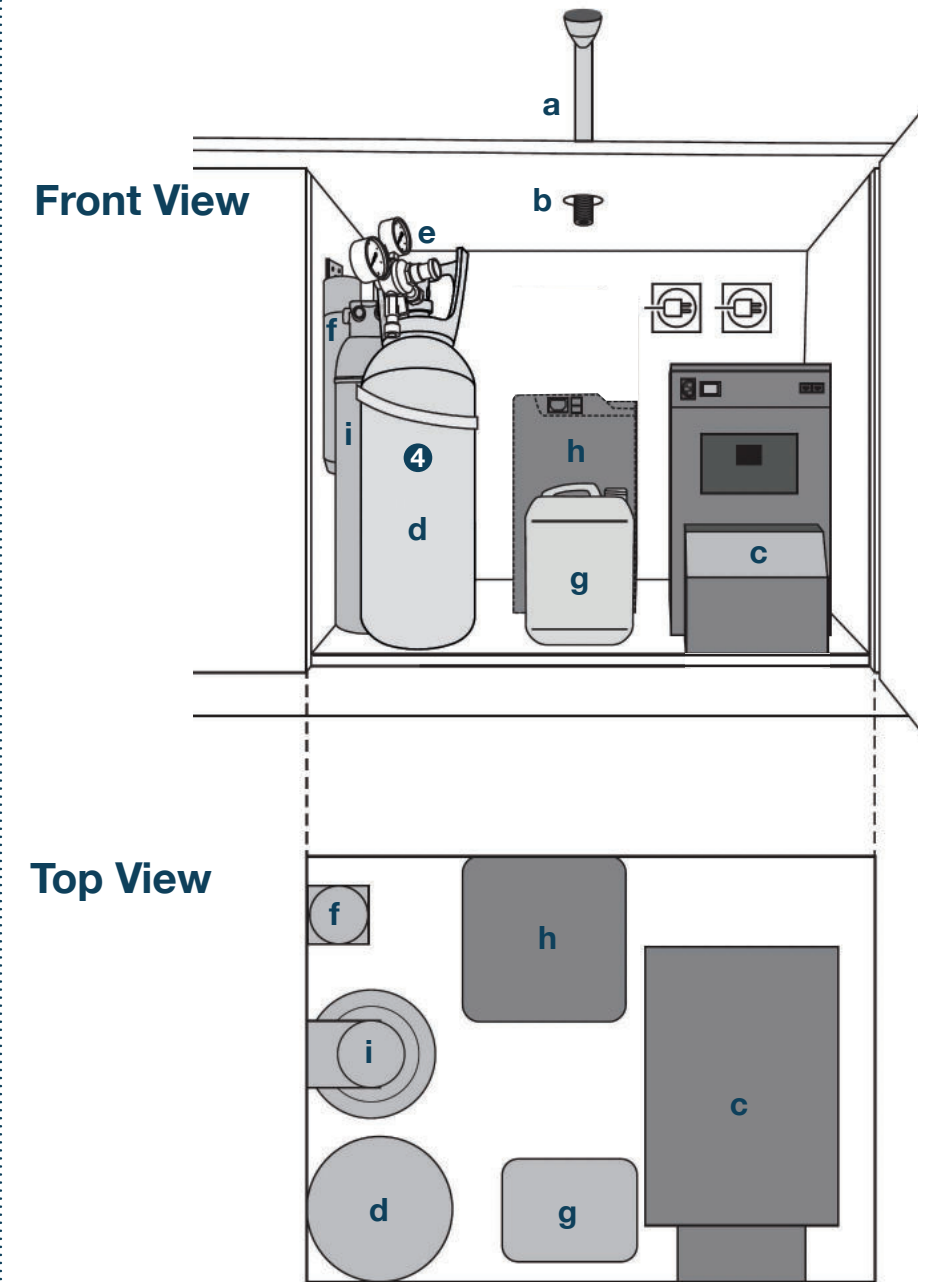

Figure 2



Easy Access Panel – Optional

Two installation options:

- Angled
- Flat: on countertop / Flat: on cabinet front

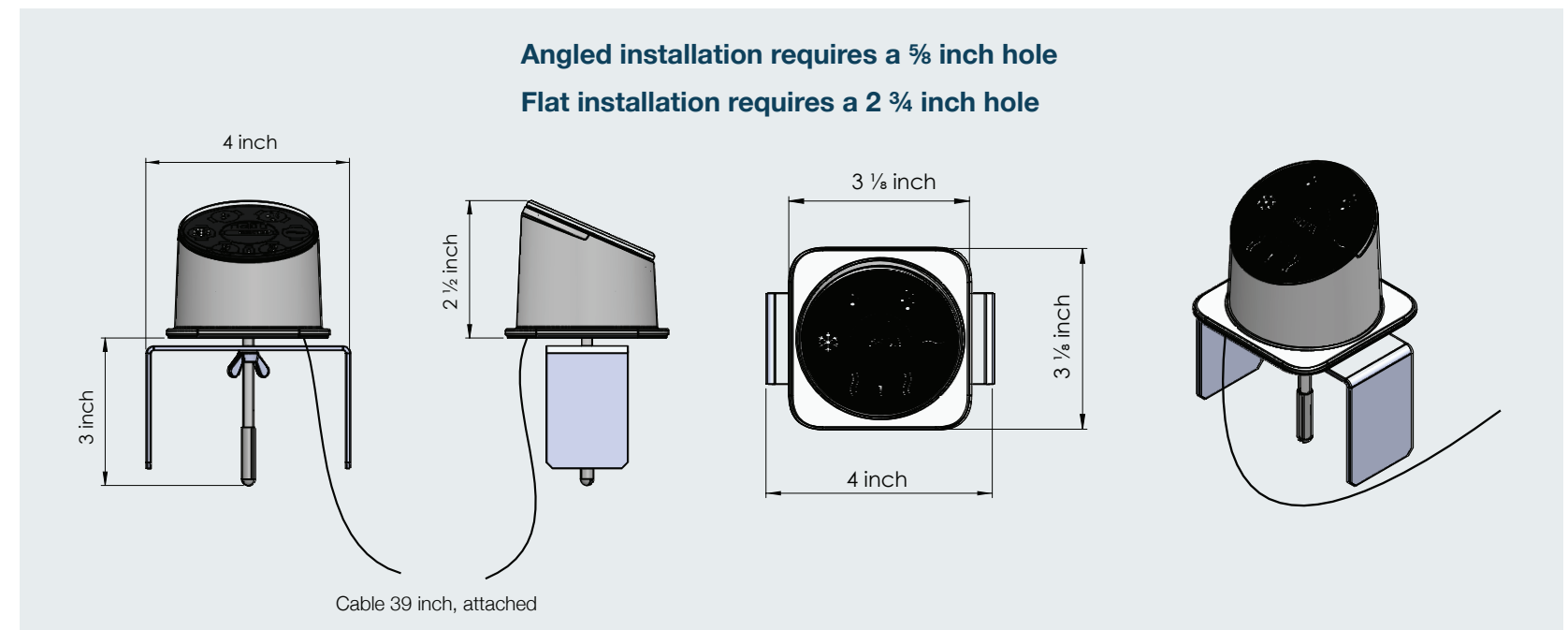

Approved Methods of Cabinet Ventilation

The cabinet requires **two vents**, one for exhaust and one for air intake.

The exhaust is on the front of the chiller and comes standard with a shroud that forces the hot air down.

If the base cutout is not possible the shroud can be replaced with an optional air guide plate that pushes the air forward requiring a matching cut out in the door.

The intake requires a 24 square inch opening to let fresh air in a free and unobstructed area.

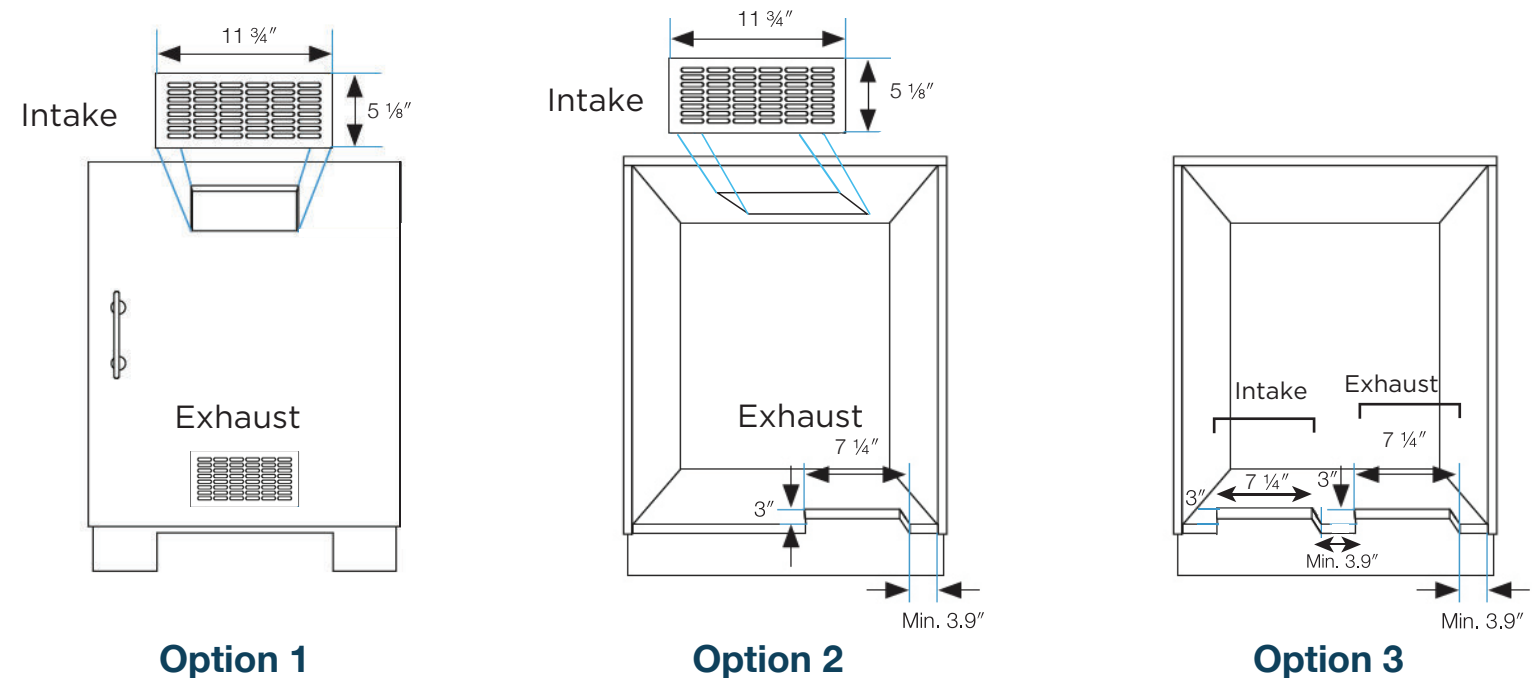

Interior temperature of the cabinet must not exceed 90°F or 32°C.

Approved Method of Cabinet Ventilation

For Cabinets Lacking a Base for Equipment Placement

If your cabinet doesn't have a base for equipment placement, it's advisable to either acquire a dolly on its own (Figure 1) or opt for a combination of a dolly and an Air Guide Plate (Figure 2).

The cabinet door requires **two vents**, one for exhaust and one for air intake.

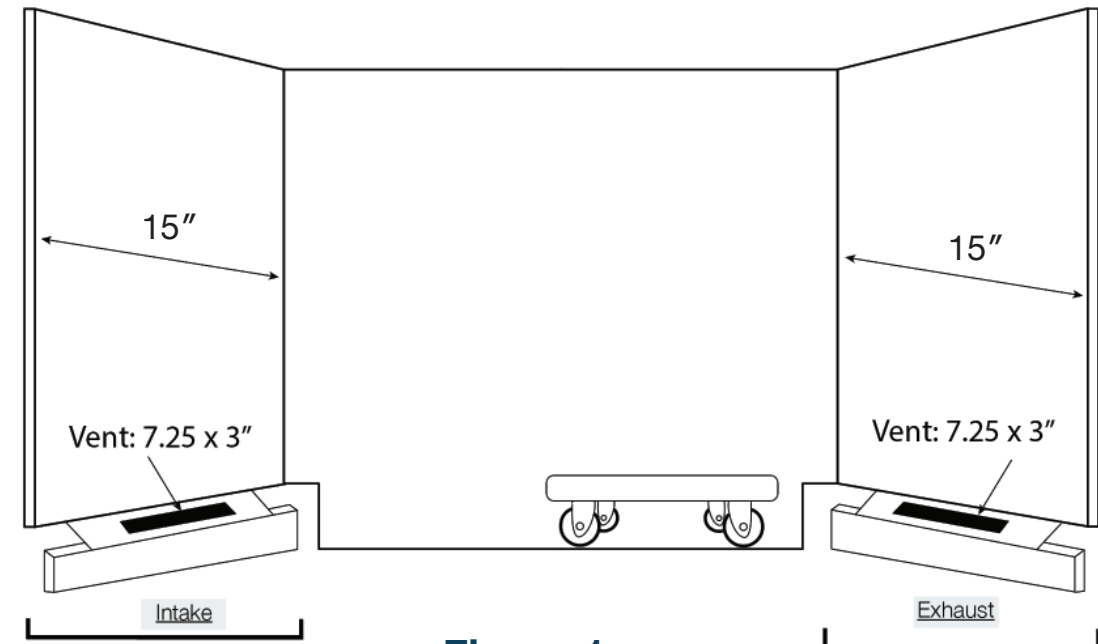

Figure 1

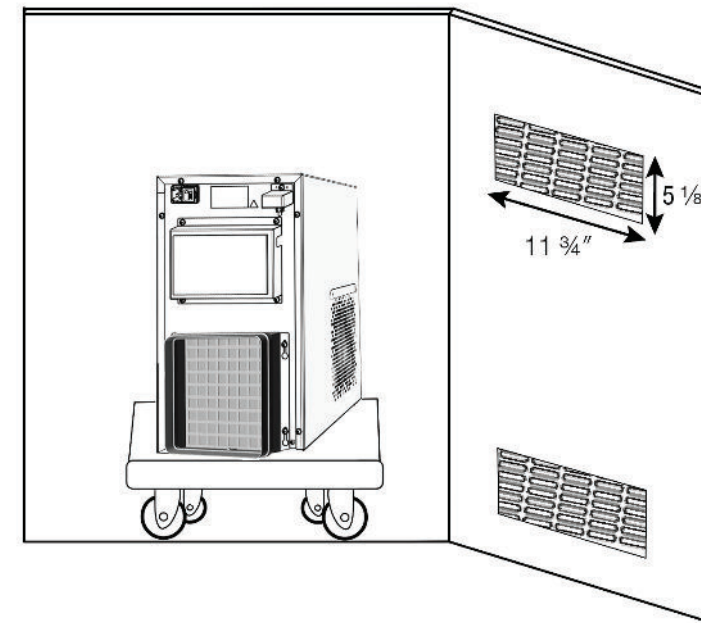

Figure 2

Interior temperature of the cabinet must not exceed 90°F or 32°C.



VIVREAU[®]

ADVANCED WATER SYSTEMS

Contact Info

Phone Number:

+1 877 999 1044

Email:

InfoUSA@vivreau.com

InfoCanada@vivreau.com

Or visit vivreauwater.com