

# VIVREAU®

## Extra I-Tap Cut Sheet

Stylish tap for space-saving installation in the worktop. Powerful technology, hidden in the base cabinet. Flexible device variants for use in offices or in the healthcare sector.

Project: \_\_\_\_\_

Item#: \_\_\_\_\_

Quantity: \_\_\_\_\_



### Standard features:

- Unlimited ambient water or chilled still, sparkling and semi-sparkling water
- Vivreau's ThermalGate™ feature protects against retrograde contamination from external sources
- Choice of tall or short tap
- Focus on sustainability R290: natural refrigerant and extremely low power consumption

### Options & Accessories:

- Easy Access Panel
- HygienePlus solution
- 2 heights – Short tap and tall tap
- Waste water container (if drain pipe is not available)

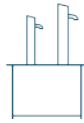

### Ideal for:

Hospitals, Executive Lounges, Bars, Staff Rooms, Wellness and Spa Areas

### Average output capacity:

- 85 l/h



AMBIENT



CHILLED STILL



SEMI-SPARKLING



SPARKLING

Specifications	
Design	Tap system
Unit dimensions (W X H X D)	Tall tap: (H x D; Diameter) 17 ¾ x 6 ¾; 2 ¾ inch Short tap: (H x D; Diameter) 15 ½ x 6 ¾; 2 ¾ inch
Weight	84 lbs (cooler carbonator) Tall tap: 5 lbs   Short tap: 4 lbs
Millwork and Ventillation	
Fits into base cabinet with the following dimensions (W X H X D)	24 X 30 X 24 inch
Tap head clearance	Tap height plus additional 4" clearance for operation
<b>NOTE:</b> Tap must be mounted directly above the main system	
Electrical	
Electrical Requirement	(1) 20amp electrical circuit GFCI recommended (NEMA 5-20R) 120V, 60Hz (11 amps)
CO2	
CO2 Tank (customer supplied)	If connecting to a bulk or existing CO2 system, a CO2 line terminating at a ¼" barbed shutoff valve must be available within 40" of the System installation site, 100psi minimum pressure.
Plumbing	
Water connection	1 potable ½" cold water supply terminating in a ½" ball valve with a ½" female pipe thread
Waste water connection	Waste water pipe or Waste water container
Drip Tray Drain	Drain to connect ½" ID - ¾" OD drip tray tube
Minimum water pressure	50 PSI
Minimum water flow	80 gallons, 302.8 L per hour
<b>NOTE:</b>	
• Any incoming water temperature above 60°F (15.5°C) will severely compromise the ability for the system to maintain a cold water supply.	

### Consultant specification:

Water Dispensing System, single tap, 10 ¼" or 13" dispensing height, mains-fed, fully-integrated undercounter cooler/carbonator, 4 water types - ambient, chilled still, medium sparkling, classic sparkling water, 22.5 gallons/hour output, Aquastop anti-leak sensor, optional HygienePlus filter and standard ThermalGate retrograde protection, ETL and NSF certified, natural refrigerant R290, 510W max power consumption (24"W x 24"D x 30"H cabinet space required for installation)



All Vivreau products are Intertek and NSF Certified.

# Extra I-Shape Worktop Cutout

**THIS DRAWING IS NOT TO SCALE**

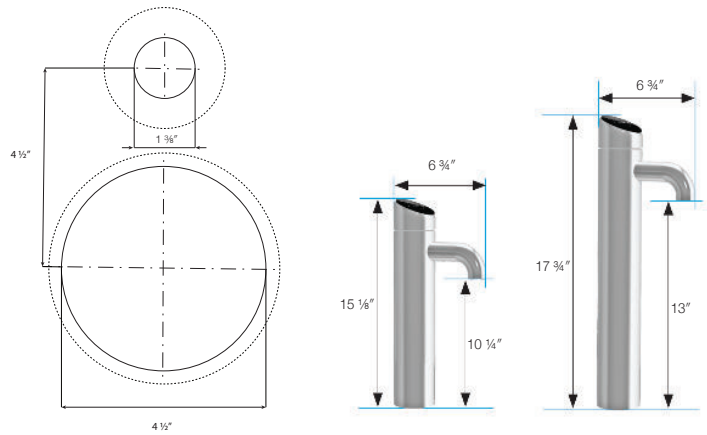

## Approved Methods of Cabinet Ventilation

The cabinet requires **two vents, one for exhaust** and **one for air intake**. The exhaust is on the front of the chiller and comes standard with a shroud that forces the hot air down. If the base cutout is not possible the shroud can be replaced with an optional air guide plate that pushes the air forward requiring a matching cut out in the door. The intake requires a 24 square inch opening to let fresh air in a free and unobstructed area.

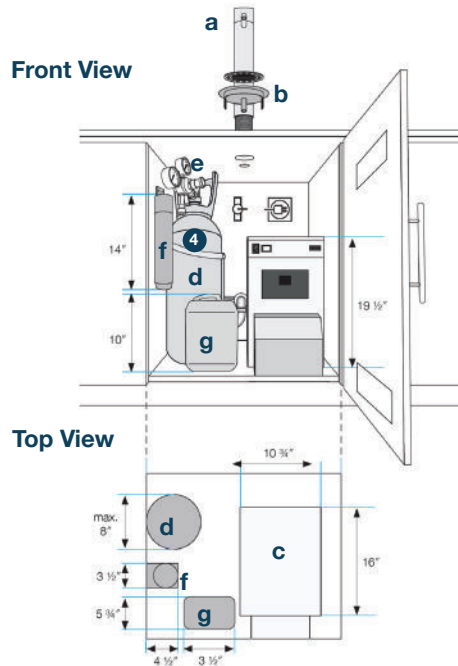
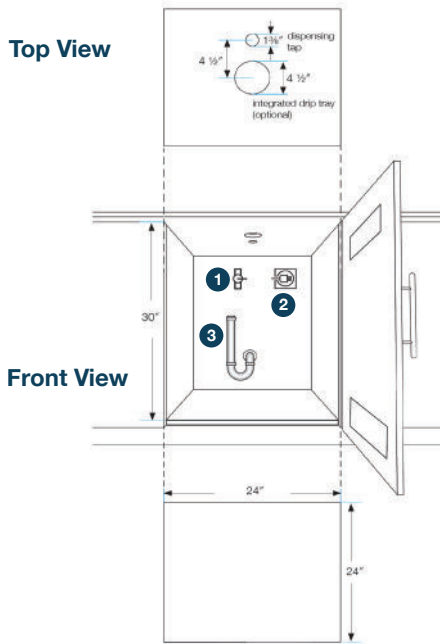
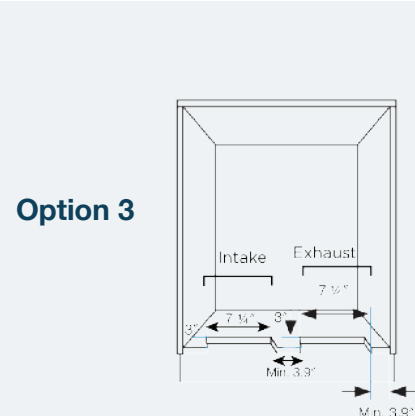
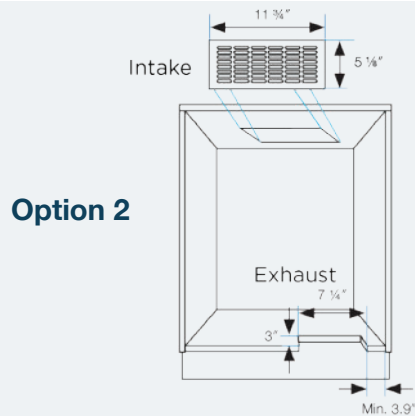
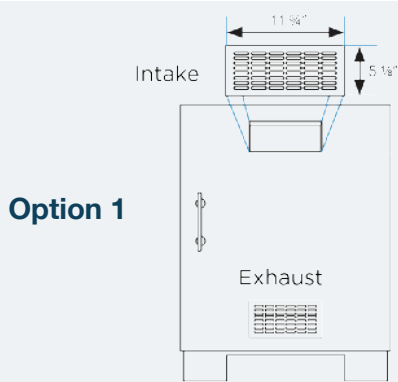

### Drip Tray (integrated)

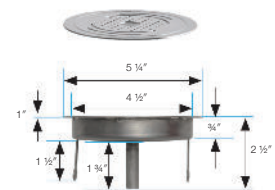

### Cooler-carbonator



- 1 Water Connection
- 2 Electrical Connection
- 3 Waste Water Connection
- 4 CO2 (customer supplied)

- a. Dispensing Tap
- d. CO2 Tank
- b. Integrated Trip Tray
- e. CO2 Pressure Regulator
- c. Cooler-Carbonator
- f. Filter
- g. Optional Waste Water Container