

V3-202 Cut Sheet

Our high volume bottling systems have redefined the way businesses consume water, eliminating the need for costly and wasteful single-serve bottled products while providing exceptionally high quality, mains-fed filtered and chilled water.

Project: _____

Item#: _____

Quantity: _____



Standard features:

- Dispenses high volumes of chilled still and sparkling water on demand
- High performance ice-bank refrigeration
- LED control panel with alarms for CO2 bottle replacement and internal drip tray
- 0.2 sub-micron activated carbon block filtration
- Filling takes approx. 16 sec / 750 ml bottle
- 100 Designer Vivreau bottles comes standard with unit

Options & Accessories:

- Custom branding and messaging is available for reusable bottles to convey your commitment to the environment. Multiple bottle styles to choose from.
- Antimicrobial films to be attached on the touch handles.
- Natural flavors available to provide a health-minded alternative to sugary sodas and expensive fruit infused service.

Ideal for:

Conference & Meeting Facilities, Country Clubs, Healthcare, Higher Education, Hospitality, Parks & Destination, Hotels, Restaurants, Refreshment Services, Senior Dining, Sports and Leisure Facilities

Average output capacity:

53 gal/200 L per hour of chilled still or sparkling water



STILL



SPARKLING

Specifications	
Design	Floorstanding
System dimensions (W X H X D)	23 3/8" X 33 3/8" X 23 1/8" inch 59.3 X 84.7 X 58.7 cm (system cabinet) 7" X 19 1/2" X 8 3/5" inch 17.7 X 49.5 X 21.8 cm (tap)
Weight	165 lbs 74.8 kg (system cabinet) 4.4 lbs 2 kg (tap)
Millwork	
Millwork	Worktop cutout on page 2
Electrical	
Electrical Requirement	(1) 20amp electrical circuit GFCI recommended (NEMA 5-20R) 120V, 60Hz (11 amps)
CO2	
CO2 (customer supplied)	If connecting to a bulk or existing CO2 system, a CO2 line terminating at a 1/4" barbed shutoff valve must be available within 40" of the System installation site, 100psi minimum pressure. 20 lbs CO2 cylinder recommended to fit inside cabinet of unit.
Plumbing	
Water connection	1 potable 1/2" cold water supply terminating in a 1/2" ball valve with a 1/2" female pipe thread
Drip tray drain	Customer needs to supply a rigid vertical pipe that drains to a properly trapped drain according to local codes. The vertical pipe for the drip tray drain must be located inside the installation cabinet and must be at least 1 1/4" ID.
Minimum water pressure	50 PSI
Minimum water flow	80 gallons, 302.8 L per hour
NOTE: Any incoming water temperature above 60°F (15.5°C) will severely compromise the ability for the system to maintain a cold water supply.	

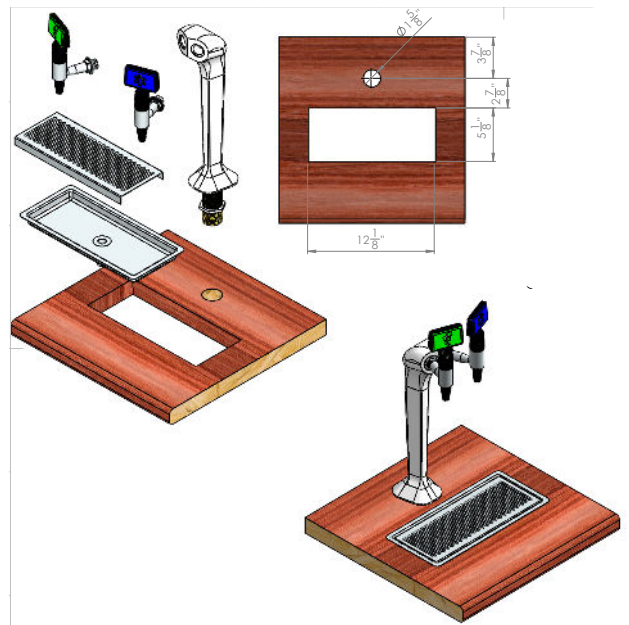
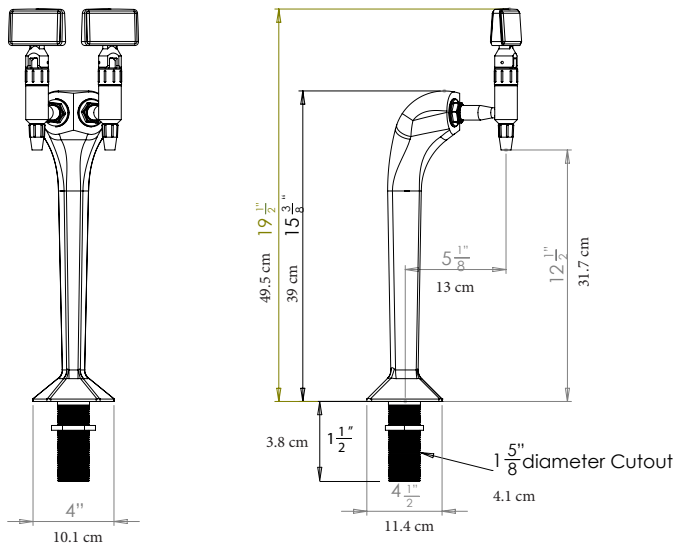

Equipment Dimensions

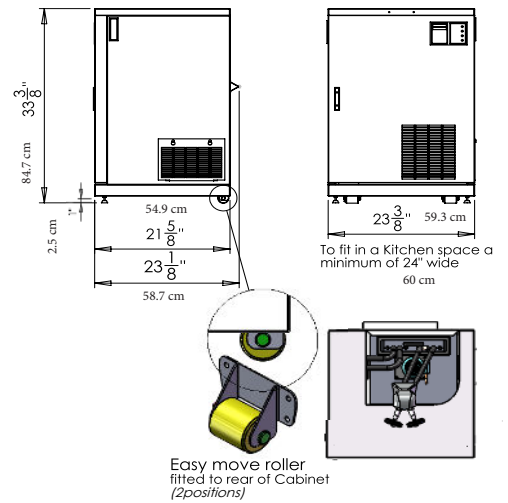
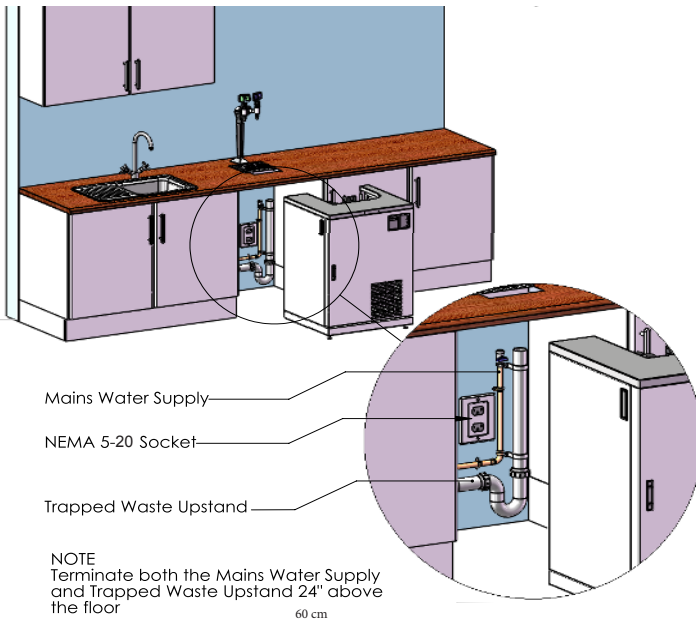
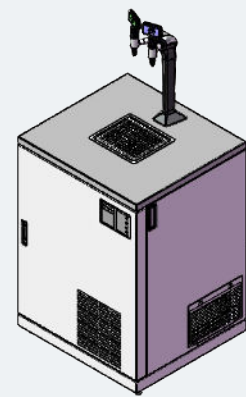

Consultant specification:

Vivreau High Volume Water Bottling System, dual tap, undercounter cabinet, self-contained ice bank refrigeration system, advanced micro-filtered, chilled still and sparkling water, twin tap with removable nozzles & stainless steel drip tray, accommodates up to 20 lb CO2 cylinder (cylinder not included), front feet, rear rollers, x1 20amp electrical receptacle (5-20 R) 120V 60Hz (11 amps), NEMA 5-20R, ETL, NSF (for indoor use only)