



Vi Tap 2H

Specification Sheet

VIVREAU®



Vi Tap Dispenser

Single Serve Dispenser | Vi 2H

- New improved modern designed dispense tap
- High performance icebank refrigeration system delivering 80 liters of cold water per hour
- Touch control dispense
- Designed to fill sports bottles without the need for font extension
- Perfect water flow with zero splash
- Plumbed to waste flush fitting drip tray
- Removable dispense nozzle for improved hygiene
- Anti-flood detection as standard



Please Read First

This Vivreau Water Dispenser is unlike any other water system you may have worked with and requires the following to install.



Millwork

Below Counter - Standard Cabinet Dimensions

Width 30" - Depth 24" - Interior Height 29 ½"

4 holes will need to be cut into the countertop to accommodate the taphead - See p.8

Above Counter - Tap Head Clearance

Tap Height: 13" - Additional 6" clearance needed for operation

NOTE: Tap must be mounted directly above the main system

Cabinet Ventilation

All vents must open to fresh air in a free and unobstructed area. 24 Square inches of opening is required for each of the top and bottom vents



Plumbing

Water Connection

1 potable ½" cold water supply terminating in a ½" ball valve with a ½" female pipe thread.

NOTE: Please ensure that there is sufficient room for a 12" long fitting to be connected to the shut-off valve. Top of waste up stand should be a maximum of 24" from the base of the unit.

Electrical

Outlets

(2) 20amp electrical circuit (5-20R) 120v, 60Hz (13 amps & 11 amps)

Electrical circuit is to be located in base cupboard unit at high level in either left or right corner (not beneath dispense tap.)

CO2 (Customer supplied)

Design

Since the equipment is installed in component form, there are varying configurations for installation - Third party vents or other design solutions are okay as long as the overall size of the vented area is maintained.

Water Supply

- Minimum water pressure 50 PSI
- Minimum water flow 80 Gallons per hour

NOTE: Any incoming water temperature above 60°F will severely compromise the ability for the system to maintain a cold water supply

Drip Tray Drain

A rigid vertical pipe that drains to a properly trapped drain according to local codes - The vertical pipe for the drip tray drain must be located inside the installation cabinet and must be at least 1 ¼" ID

Please refer to the rest of this document for further details regarding each specification. Contact Vivreau with any questions: +1 877 999 1044

Vi 2H - North America Specification Sheet

Product Dispensed:

Advanced micro-filtered, chilled still and sparkling water

Application:

Designed typically to be installed within existing cabinet units in an office break area for staff refreshments

Equipment Dimensions:

Due to the fact that the equipment is installed in component part form, there are varying configurations for installation. As a guideline, a cabinet to the following dimensions will be sufficient:

- Width 30"
- Depth 24"
- Interior Height 29 ½"

The following services are required to be supplied by the customer and must be available prior to installation:

Millwork

- Dispense Taps (Drilling templates attached)
- Dimensions Height 13" plus additional 6" clearance for operation
- Cut out for Tap Stem and Drip Tray Drain as per attached template
- If the system is to be installed in an enclosed space or cabinet adequate ventilation must be provided.

(failure to provide ventilation will cause system failure)

Electrical

(2) 20amp electrical circuit (5-20R) 120v, 60Hz (13 amps & 11 amps)

CO2

- CO2 (customer supplied) CO2 must be available for installation.
- *If connecting to a bulk or existing CO2 system, a CO2 line terminating at a 1/4" barbed shutoff valve must be available within 40" of the System installation site, 100psi minimum pressure.

CO2 Supply
1/4" Barbed Shutoff



Plumbing

- 1 potable 1/2" cold water supply terminating in a 1/2" ball valve, 1/2" female pipe thread. (ball valve must be accessible for service and installation).
*The Vivreau system incorporates back flow prevention, any additional back flow devices required by local or state code must also be supplied by the customer prior to installation. There should not be any other filters/pre-filters before the Vivreau system.
- Minimum water pressure 50 PSI
- Minimum water flow 80 Gallons per hour
- Drip Tray Drain: Customer needs to supply a rigid vertical pipe that drains to a properly trapped drain according to local codes. The vertical pipe for the drip tray drain must be located inside the installation cabinet and must be at least 1 1/4" ID.

Female Water Supply
1/2" Threaded Ball Valve



Location of Services: (all services must be accessible for installation and service)

- Please ensure all services are kept within 40" of the system location. Unless otherwise specified
- Electrical circuit is to be located in base cupboard unit at high level in either left or right corner (not beneath dispense tap.)
- Water shut-off valve to be located at low level. Please ensure that there is sufficient room for a 12" long fitting to be connected to the shut-off valve. Top of waste up stand should be a maximum of 24" from the base of the unit.
- Top of waste circuit should be located a minimum of 6" Inches below the work surface the ViTap will be installed in.

*****The tap must be mounted on the work surface directly above the main system.*****

Insulation:

Please ensure that all water pipes feeding the Vivreau System are correctly insulated to ensure that the water does not heat up within the pipes prior to entering the Vivreau system. This is essential for water quality reasons.

Vi 2H Hot Water Delivery and System Recovery

- 48 cups /11 L of hot water/hr
- 1.7 liter /0.45 gallon direct hot water pour
- Complete hot water recovery time = 3.5 min

Vi 2H Electrical consumption

- Energy consumed with consistent operation over 12 hrs = 37.2 Kwh
- Energy consumed with consistent operation over 1 hr = 3.1 Kwh
- Energy consumed in 'sleep mode' over 24 hrs = 2.8 Kwh

Vi 2H Electrical Requirement:

- 2, 20amp electrical socket (5-20 R) 120v 60Hz (13 amps & 11 amps)



Example Cabinet Measurements

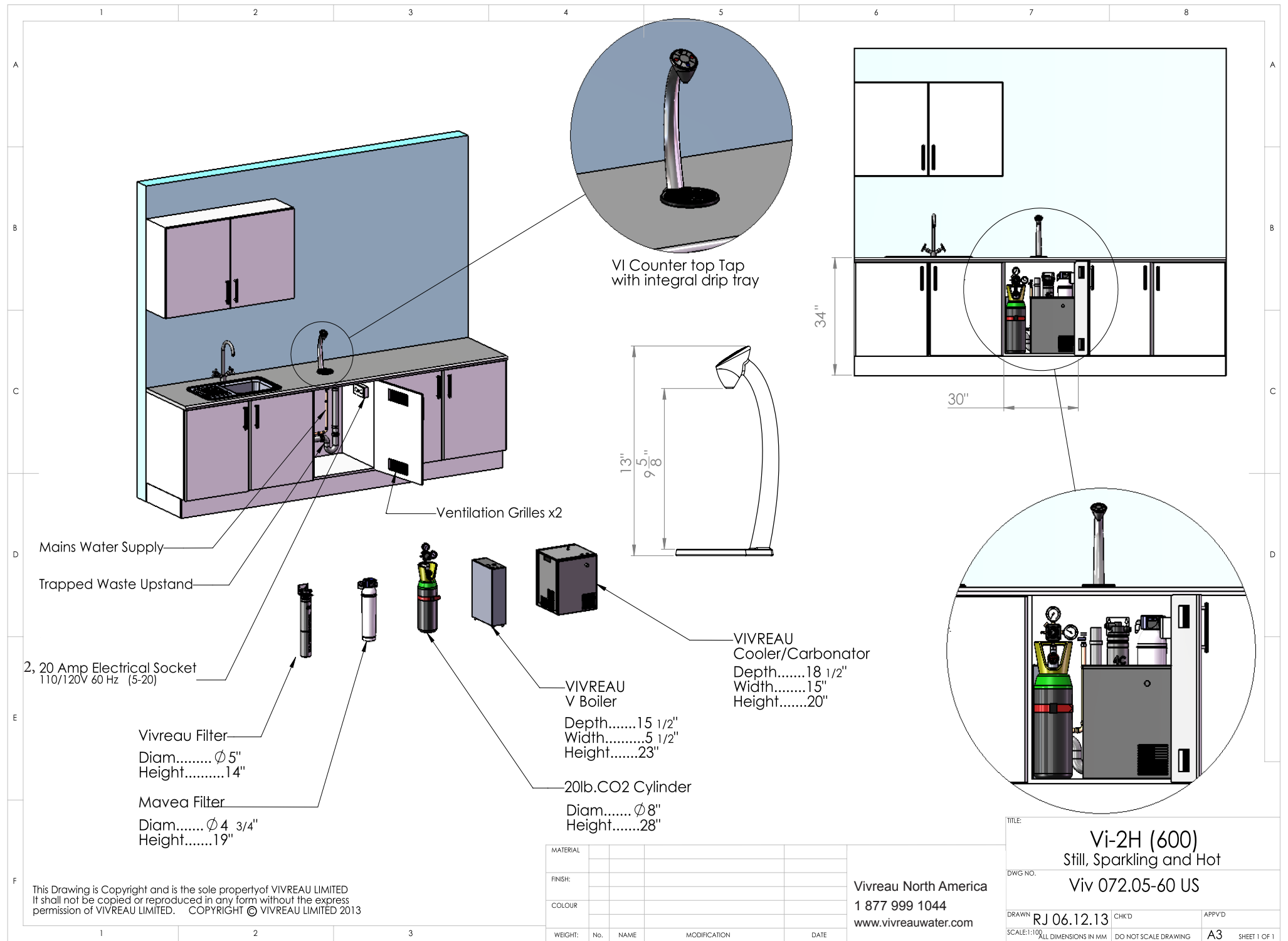

Vi Tap Standard View for Worktop Cutout

NOTE: There are four holes to be drilled.
2x mounting holes, **1x** drain hole, **1x** tap hole

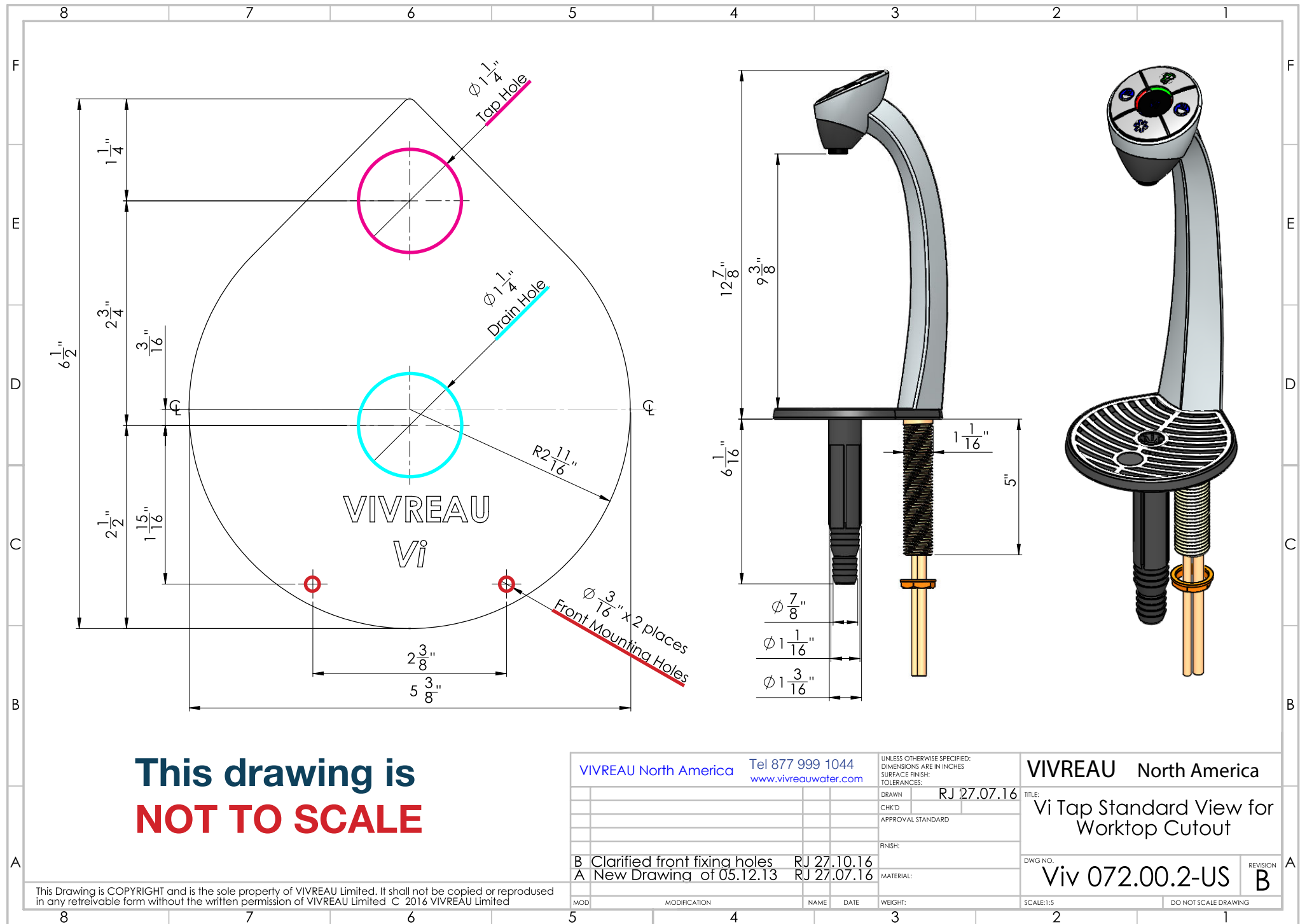

This drawing is NOT TO SCALE

This Drawing is COPYRIGHT and is the sole property of VIVREAU Limited. It shall not be copied or reproduced in any retrievable form without the written permission of VIVREAU Limited. © 2016 VIVREAU Limited

VIVREAU North America Tel 877 999 1044 www.vivreauwater.com		UNLESS OTHERWISE SPECIFIED: DIMENSIONS ARE IN INCHES SURFACE FINISH: TOLERANCES:	VIVREAU North America
DRAWN	RJ 27.07.16	FINISH:	TITLE: Vi Tap Standard View for Worktop Cutout
CHK'D		APPROVAL STANDARD	DWG NO. Viv 072.00.2-US
APPROVAL		MATERIAL:	REVISION B
B Clarified front fixing holes	RJ 27.10.16	WEIGHT:	SCALE:1:5
A New Drawing of 05.12.13	RJ 27.07.16	DO NOT SCALE DRAWING	

Approved Methods of Cabinet Ventilation

PLEASE NOTE

All vents must open to fresh air in a free and unobstructed area

24 square inches of opening is required for each of the top and bottom vents. 48 square inches in total

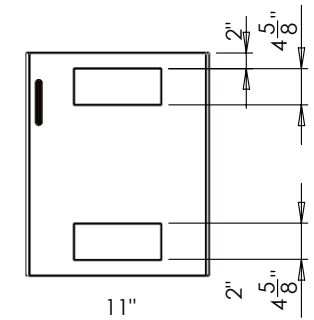

Cut-out detail for the available 12" VIVREAU grill, shown in a 23.5" (24") wide door

4). Countertop cutout can be used as a top ventilation option

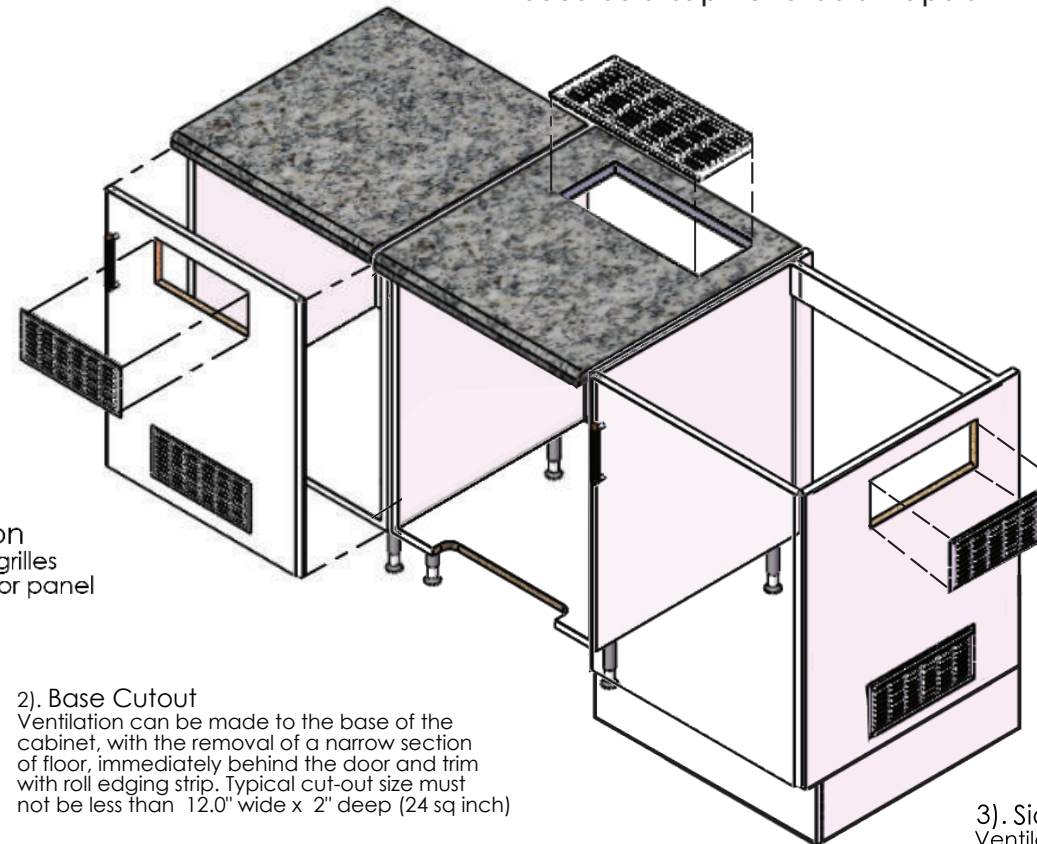

1). Front Ventilation
Showing Ventilation grilles cut in a standard door panel

2). Base Cutout
Ventilation can be made to the base of the cabinet, with the removal of a narrow section of floor, immediately behind the door and trim with roll edging strip. Typical cut-out size must not be less than 12.0" wide x 2" deep (24 sq inch)

3). Side Ventilation
Ventilation grilles cut in the side of a standard cabinet. The grilles may be fitted on either side
Does not open into an enclosed cabinet.

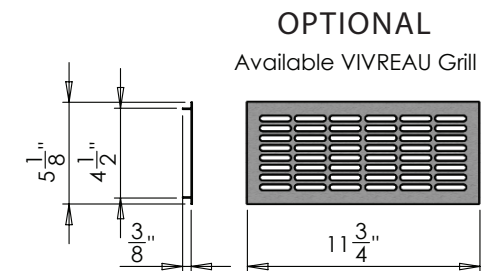

The cabinet may be ventilated in several different ways to prevent excessive heat build up. The methods shown all take advantage of natural circulation by placing two grilles or cut-outs; one near the base and the other at the top of the enclosure.

VIVREAU[®]

ADVANCED WATER SYSTEMS

Contact Info

Phone Number:

+1 877 999 1044

Email:

InfoUSA@vivreau.com

InfoCanada@vivreau.com

Or visit vivreauwater.com